

# Lighting Towers

GENUINE  
COMPONENTS

## Kubota Engine Stamford Alternator



BlueDee® offers 4 and 6 lamp robust mobile lighting towers that can extend up to 9m high to provide even illumination over large areas. The units are very stable in operation due to adjustable stabilizers fitted as standard. The high quality of materials used in manufacture ensure that all units are compact and lightweight with fully galvanised mast sections and special coatings providing maximum durability and resistance to weather conditions.

### Features:

Kubota engine and Stamford alternator for reliable operation and long service life.

Single hand-operated safety winch to raise/lower the telescopic mast sections from the horizontal position to full 9M height with a special tilt spring used to start the lowering of the mast back to the travel position. The mast can be rotated from ground level through 360 deg for accurate final positioning.

Automatic shutdown protection is provided against low oil pressure and high engine temperature. A control panel with key start/stop provides an operator with easy access to all controls.

Plug-in electrical components with Mil-spec connectors for easy replacement by unskilled operators. Individual lighting circuits allow replacement of components without interrupting on-site illumination.

Rugged floodlight housings with end-lamp support, high performance aluminium reflectors and tempered lenses. Floodlights can be mounted on the cross bar for travelling.

Heavy-duty tubular steel trailer frame and weatherproof/acoustic enclosure applied with automotive (5 coat + iron phosphate pre-treatment) corrosion resistant coatings.

95 litre (25 imp gal) fuel tank provides up to 60 hour continuous operation between refuelling.

Single-point lifting eye and tie-down rings ensure safe and balanced positioning and transport.

**BlueDee®**  
Power Generation

# Specifications

## Technical Data

50Hz, 1500 RPM

		MLT4	MLT6
ENGINE	Kubota Model	D1105-BG	D1105-BG
	Type	3-Cylinder, Water Cooled	3-Cylinder, Water Cooled
	Stamford Alternator	BC 164B-16	BC 164B-16
LIGHTING AC GENERATOR	Operating Voltage (V)	220, Single Phase, $\pm 1.0\%$	220, Single Phase, $\pm 1.0\%$
	Power Factor	0.8 (33.5 Amps)	0.8 (33.5 Amps)
	Continuous Rating (kW)	5.9 (7.4 kVA)	5.9 (7.4 kVA)
	Auxiliary Power (220V)	2 No. Multi-size Sockets	2 No. Multi-size Sockets
	Type of Lamp	Metal Halide Lamp (E40)	Sodium Vapour (E40)
MAST	No. of Lamps	4 x 1000 Watt	6 x 1000 Watt
	Type	3-section, Telescoping	3-section, Telescoping
	Total Height / Rotation	9 M / 360°	9 M / 360°
Operation		Hand Safety Winch	Hand Safety Winch

## Physical Data

	MLT4	MLT6
Ingress Protection	IP 23	IP 23
Acoustic Pressure (dBA)	70 dBA at 7 M	70 dBA at 7 M
Fuel Tank Capacity (L)	95	95
Gross Weight, inc. Trailer (Kg)	730	730
Tyres	6 x 14 Cross Ply on 4½ J Rims	6 x 14 Cross Ply on 4½ J Rims
Dimensions LxWxH (closed) (M)	4.5 x 1.5 x 1.7	4.5 x 1.5 x 1.7
Dimensions LxWXH (open) (M)	3.1 x 2.6 x 9.0	3.1 x 2.6 x 9.0
Run Time (Hrs)	60	60

BlueDee® reserves the right to change the design or specifications without notice and without any obligation or liability.

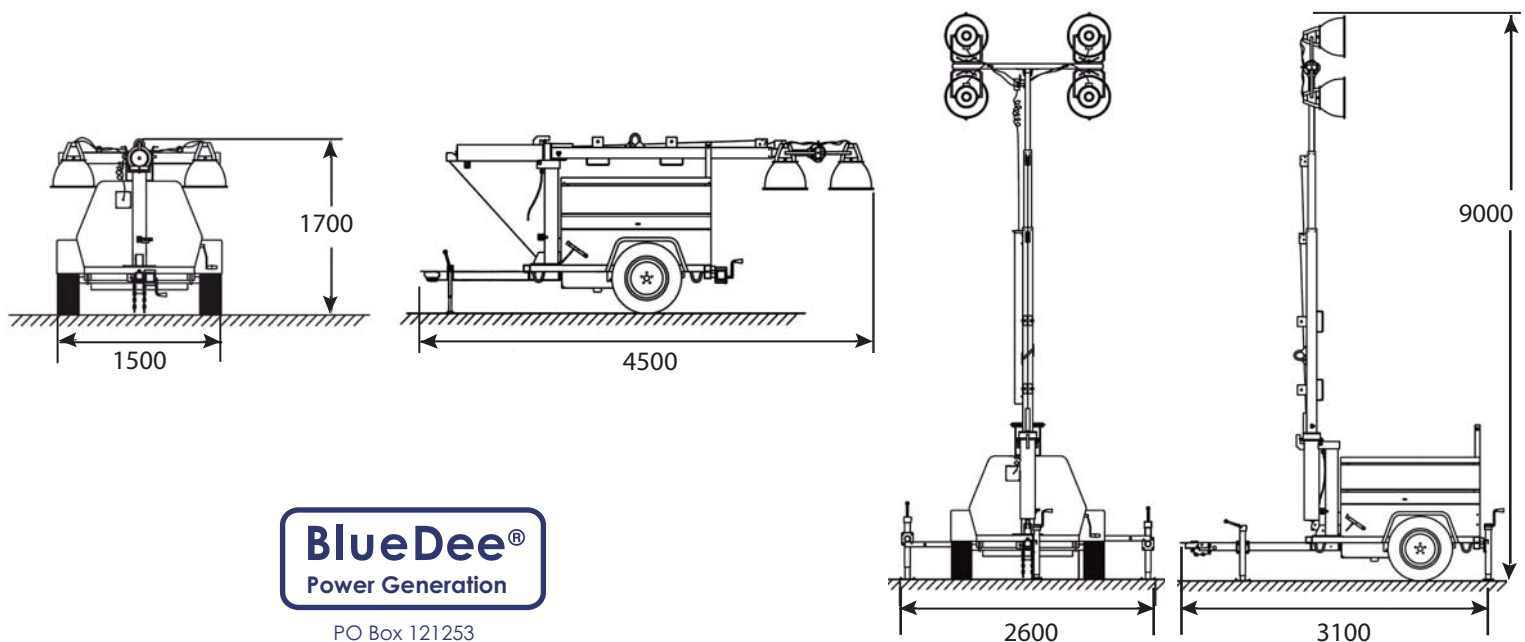

**BlueDee®**  
Power Generation

PO Box 121253  
Dubai, UAE

Tel: +971 (0)4 289 5930

Fax: +971 (0)4 289 5931

Email: [equipment@bluedeellc.com](mailto:equipment@bluedeellc.com)

[www.bluedeellc.com](http://www.bluedeellc.com)